

HEAT EXCHANGE OF GAS-DISPERSE SYSTEMS IN A UNIFORM ELECTRIC FIELD

V. V. Pushkov, Z. R. Gorbis,
and M. K. Bologna

UDC 536.24:541.182.3:537.212

The results are presented for an experimental study of the effect of the self-oscillating motion of a disperse material, produced by the effect of a uniform electrostatic field, on the intensity of heat exchange during free convection in a closed volume.

The method of intensification of heat exchanged based on the effect of electric fields is distinguished by high efficiency and requires very slight energy expenditures. Its potentialities have been rather fully revealed in application to processes of heat exchange in homogeneous media (dielectric liquids and gases) and in emulsions and suspensions [1, 2]. The effect of an electric field on heat exchange in gas-disperse systems has not been studied, however, although the fact of the self-oscillating motion of solid particles in the electric field of a flat capacitor is the subject of theoretical studies [3] and finds practical application in instrument manufacture [4] and in granulometric analysis [5].

For the specific filling of this gap the authors have attempted to clarify the possibilities of the intensification of heat exchange in a gas suspension confined in a closed volume through the effect on the disperse system of electric fields of different strengths. The oscillatory structure formed in this case can be considered as the limiting structure of a flow system with zero average velocity (with respect to the flow rate) of the solid and gaseous phases at concentrations characteristic for the flow of a gas suspension.

The experiments were conducted in a horizontal capacitor (Fig. 1) for which a transparent confining ring 1 served as the lateral surface. The temperature drop between the heat-emitting disk 2 and the high-temperature electrode-cooler 4 was kept constant. The temperature of the disk and ring was monitored with thermocouples while that of the high-voltage electrode was taken as equal to the temperature of the thermostatic liquid (transformer oil) in the cooler. The presence of the guard heater R_2 allowed one to assume that the heat emitted by the main heater R_1 , except for losses through the ring, is taken up by the cooler.

The conductive and convective heat losses through the thermally and electrically insulating ring were measured directly and also calculated and allowed for in the analysis of the experimental data. A stabilized rectifier which provided smooth regulation of voltage of both polarities was used as the source of high voltage.

Preliminary experiments on the selection of the dispersed material showed that the use of dielectric particles to create the gas suspension is not possible. The self-oscillating motion of particles of barium oxide, corundum, and glass observed at first soon changed to the motion of whole aggregates and to clearly expressed structure formation. Here the particle sizes were varied within wide limits: from 1-3 μ for glass to 500 μ for barium oxide. The most suitable materials from the standpoint of stability of motion proved to be powders of metals, semiconductors, graphite, and several electrically conducting minerals.

The manganese minerals psilomelane ($\rho = 3100 \text{ kg/m}^3$; $\sigma = 0.1 \Omega^{-1} \cdot \text{m}^{-1}$) and pyrolusite ($\rho = 4300 \text{ kg/m}^3$; $\sigma = 0.1 \Omega^{-1} \cdot \text{m}^{-1}$) were used from considerations of mechanical strength and simplicity of obtaining powders of monofraction composition by the sieve method. The effects of the field strength, concentration

Institute of Applied Physics, Academy of Sciences of the Moldavian SSR. Odessa Technological Institute of the Refrigeration Industry. Translated from *Inzhenerno-Fizicheskii Zhurnal*, Vol. 27, No. 2, pp. 253-259, August, 1974. Original article submitted August 15, 1973.

©1976 Plenum Publishing Corporation, 227 West 17th Street, New York, N.Y. 10011. No part of this publication may be reproduced, stored in a retrieval system, or transmitted, in any form or by any means, electronic, mechanical, photocopying, microfilming, recording or otherwise, without written permission of the publisher. A copy of this article is available from the publisher for \$15.00.

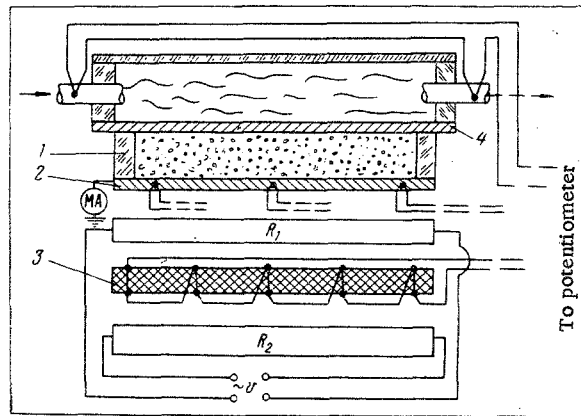

Fig. 1. Diagram of instrument: 1) confining ring; 2) heat-emitting plate containing thermocouples; 3) asbestos board insert containing a hyperdifferential thermocouple to monitor the heat flux between heaters R_1 and R_2 ; 4) high-voltage electrode-cooler.

of the dispersed component, particle size, and size of the interelectrode gap on the heat exchange in an electric field were studied for these substances.

The experiments were conducted under conditions of a stationary thermal mode with a constant temperature head $t_{1wa} - t_{2wa}$. The power of the main and guard heaters, the temperatures of the heat-emitting surface, the ring, and the transformer oil before and after the cooler, the voltage on the high-voltage electrode, and the convective current produced by charge transport by the moving particles were measured.

The experimental data were analyzed initially in the form of the dependence of the ratio Q_e/Q_0 of the heat flux intensified by the motion of the particles to the heat flux in pure air on the field strength, the size of the particles, and their volumetric concentrations (Fig. 2a). Since $\Delta t = t_{1wa} - t_{2wa} = \text{const}$, $Q_e/Q_0 = \alpha_e/\alpha_0$, where α_e and α_0 are the effective heat exchange coefficients of the disperse and pure gas media, taking into account the effect of conductive, convective, and radiative mechanisms of heat transfer under the conditions of the experiment. According to Fig. 2a an intensification of heat exchange occurs with an increase in voltage, which is connected with the observed increase in the frequency of the particle oscillations. For the psilomelane and pyrolusite fractions studied the intensifying effect is caused by the disturbance and mixing of the disperse medium and by radiative heating of the particles. The ratio of the charge acquired during contact with the electrode to the mass of the particles increases with a decrease in the diameter of the latter. For this reason the smaller particles are more mobile for different parameters β and E , which causes greater intensification of the heat transfer.

An increase in heat transfer takes place with an increase in the concentration of particles up to a certain limit corresponding on the average to the upper boundary of the existence of the gas suspension $\beta_{CR} = 2.0-3\%$ [6]. Then stabilization or even reduction of the heat exchange is observed, which is also characteristic for flowing disperse systems in the region of increased concentrations ($\beta > 3\%$) in so-called fluidized streams. The intensification of heat exchange with an increase in β in the first region is caused by an increase in the number of particles and their disturbing effect while the effect of stabilization and reduction in the intensity of heat exchange may be connected with a strengthening in the constraint, deterioration in the exchange of the fine component, and a decrease in the average velocity of the motion of the dispersed phase.

Results analogous to those presented in Fig. 2a for psilomelane were also obtained for pyrolusite, which indicates the weak effect of the electrical conductivity and density of the material in the ranges covered by the experiments. Variation in the polarity of the voltage, in the temperature head from 35 to 65°, and in the height of the gap in the range from 6 to 11 mm also did not have a marked effect on the heat exchange. Therefore the further experiments were conducted with constant negative polarity, temperature head (55°), and interelectrode gap of 9 mm.

A criterial analysis of the experimental data was conducted in the form of the dependence $Nu_e = cRe^n$:

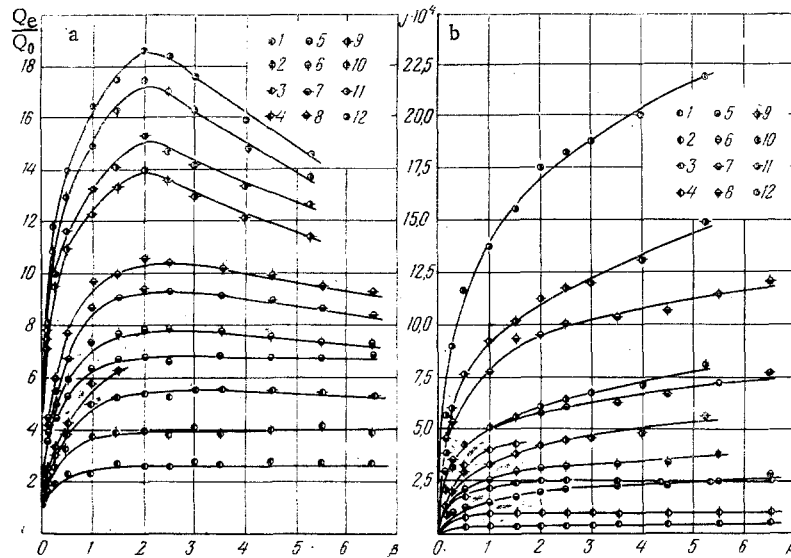

Fig. 2. Dependence of relative heat exchange (a) and density of convection current (b) on electric field strength, volumetric particle concentration, and particle size of psilomelane: 1-4) $d_p = 354 \mu$; 5-8) $d_p = 158 \mu$; 9-12) $d_p = 84 \mu$; 1, 5, 9) $E = 5.2 \text{ kV/cm}$; 2, 6, 10) $E = 6 \text{ kV/cm}$; 3, 7, 11) $E = 7.5 \text{ kV/cm}$; 4, 8, 12) $E = 9 \text{ kV/cm}$. β , %; j , A.

$$\text{Nu}_e \equiv \frac{\alpha_e d_p}{\lambda}; \quad \text{Re} \equiv \frac{\bar{v}_a d_p}{\nu}$$

The heat exchange coefficient entering into the Nusselt number was determined from the equation $\alpha_e \equiv Q_e / F(t_{1wa} - t_{2wa})$. The reduced air velocity, related to the average particle velocity by the equation

$$\bar{v}_a = \frac{\bar{v}_p \beta}{2} \quad (1)$$

is used in the Reynolds number. It is roughly assumed that a moving particle entrains a volume of air equal to half of its own volume. In this case the principal difficulty consists in the determination of \bar{v}_p . Solving the equation of motion of a single particle for the conditions under consideration without allowance for the forces of aerodynamic resistance, an estimate of which indicates that this force is negligibly small

$$\frac{d^2 x}{dt^2} = \frac{qE}{m} \pm g,$$

one can obtain an expression for the period of oscillation of the particle

$$T = \sqrt{\frac{2mh}{qE - mg}} + \sqrt{\frac{2mh}{qE + mg}}$$

Here allowance is not made for the time the particle spends at the surface of the electrode during the collision and charge exchange, a negligibly small value on the order of 10^{-4} - 10^{-5} sec [5].

The charge acquired by an electrically conducting spherical particle during contact with the electrode in a uniform electrostatic field depends on its size, the dielectric properties of the medium, and the field strength and equals

$$q = \frac{1}{6} \pi^3 \epsilon \epsilon_0 d_p^2 E. \quad (2)$$

The average velocity \bar{v}_p is connected by an obvious dependence with the height of the gap and the oscillation period: $\bar{v}_p = 2h/T$. Hence the following dependence will be valid for the reduced velocity of the air:

$$\bar{v}_a = \frac{h\beta}{\sqrt{\frac{2mh}{qE - mg}} + \sqrt{\frac{2mh}{qE + mg}}} \quad (3)$$

with the condition that the particle motion is unrestrained.

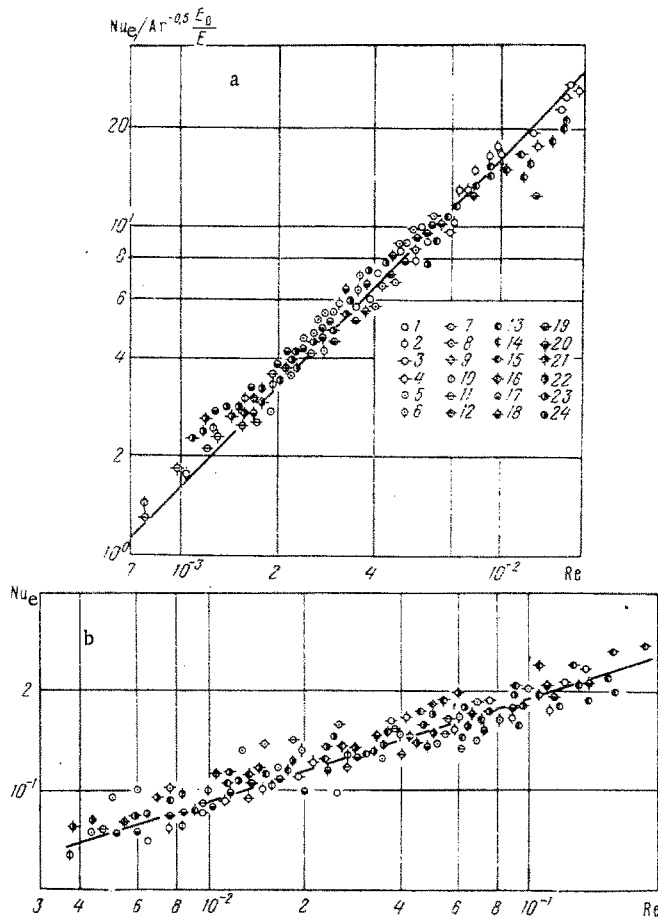

Fig. 3. Heat exchange of gas-disperse systems in a uniform electric field: a) air velocity determined from experimental values of convective current (Eq. (4)); b) air velocity determined from equation of particle motion according to Eq. (3); 1-12) pyrolusite; 13-24) psilomelane; 1-4, 13-16) $d_p = 354 \mu$; 5-8, 17-21) $d_p = 158 \mu$; 9-12, 21-24) $d_p = 84 \mu$; 1, 5, 9, 13, 17, 21) $E = 5.2$ kV/cm; 2, 6, 10, 14, 18, 22) $E = 6$ kV/cm; 3, 7, 11, 15, 19, 23) $E = 7.5$ kV/cm; 4, 8, 12, 16, 20, 24) $E = 9$ kV/cm.

Equation (3) is valid for the condition of the independent motion of the particles in a uniform electrostatic field. Under real conditions, however, the density of the current produced by the motion of the aggregate of particles generally varies nonlinearly with an increase in their concentration. Since the connection between the convective current density and the average velocity of N particles is determined by the dependence

$$j = \frac{Nq\bar{v}_p}{Fh}, \quad (4)$$

one can calculate \bar{v}_p from the experimental values of j up to $\beta \leq 2-3\%$, where the analogy between the increase in heat exchange (Fig. 2a) and the convective current density (Fig. 2b) is qualitatively preserved.

The intensity of the motion of the dispersed material and consequently of the heat exchange is closely connected with the charge transfer, therefore Eq. (4) can also be extended to the case of constrained motion. The value of \bar{v}_p obtained from (4) from the experimental value of the current can be considered as the average particle velocity with allowance for constraint. Expressing N through the concentration, we finally obtain from (1), (2), and (4) an expression for the reduced air velocity

$$\bar{v}_a = \frac{j d_p}{2\pi^2 \epsilon \epsilon_0 E}. \quad (5)$$

In the analysis of the experimental data by this method an additional effect of the voltage and the particle size was discovered, which was accounted for by the simplex E_0/E and the Archimedes number.

The voltage E_0 corresponds to the start of the self-oscillating motion of the particles and is determined with sufficient accuracy by the equation [4]

$$E_0 = \frac{51.3 \sqrt{mg}}{d_p}$$

The criterial equation

$$Nu_e = 1620 Re Ar^{-0.5} \frac{E_0}{E}$$

obtained in this way describes the heat exchange with the horizontal surface of a slot channel under conditions of electroconvection of dispersed material of pyrolusite and psilomelane with a maximum error of 10% for the condition $\beta \leq \beta_{CR}$ and is valid in the range of variation of the other parameters studied (Fig. 3a). The mean geometric diameter of the particles is taken as the determining dimension. The thermo-physical properties of the air were determined from the average temperature of the electrodes.

The necessity of the experimental determination of the convective current is a well-known drawback of the method of analysis adopted. If the gas velocity in the Reynolds number is calculated from Eq. (3) the need for an experimental determination of the convective current is removed. In this case the results are approximated with an error of up to 25% by the dependence (Fig. 3b)

$$Nu_e = 0.392 Re^{0.31}$$

It follows from the above that the self-oscillating motion of the dispersed material in a uniform electrostatic field under conditions of free convection considerably improves (by 3-18 times) the heat exchange with the gas; the intensifying effect of the field depends to a large extent on its strength and on the concentration and sizes of the particles; a limiting value of the concentration exists, approximately coinciding with the well-known value for continuous streams of a gas suspension, and exceeding it leads to stabilization of the heat exchange or to its worsening; the analogy between the transport of heat and charge makes it possible to generalize the experimental data by a single criterial dependence for the particles studied which differ in electrophysical properties.

NOTATION

E	is the electric field strength;
m and d_p	are the mass and diameter of particle;
ρ and σ	are the density and electrical conductivity of dispersed material;
β	is the volumetric concentration of dispersed phase;
T	is the period of particle oscillation;
\bar{v}_p and q	are the average velocity and charge of particles;
ϵ	is the relative dielectric permeability;
F	is the area of heat-emitting surface;
\bar{v}_a	is the reduced velocity of air;
h	is the height of gap between electrodes;
t_{1wa} and t_{2wa}	are the temperatures of heat-emitting and heat-receiving surfaces;
g	is the acceleration of free fall;
Re	is the Reynolds number;
Nu	is the Nusselt number.

LITERATURE CITED

1. B. R. Lazarenko, M. K. Bologa, I. A. Kozhukhar', A. A. Skimbov, and M. P. Zhelyaskov, Heat and Mass Transfer [in Russian], Vol. 5, Naukova Dumka, Kiev (1972).
2. M. P. Zhelyaskov, M. K. Bologa, and I. A. Kozhukhar', *Élektronnaya Obrabotka Materialov*, No. 1 (1973).
3. V. I. Goryunov and V. S. Metrikin, *Izv. Vuz., Priborostroenie*, **13**, No. 8 (1970).
4. O. A. Myazdrikov, *Atomnaya Énergiya*, **20**, No. 5 (1966).
5. O. A. Myazdrikov, Electrical Methods of Volumetric Granulometry [in Russian], *Énergiya*, Leningrad (1968).
6. Z. R. Gorbis, Heat Exchange and Hydromechanics of Disperse Continuous Streams [in Russian], *Énergiya*, Moscow (1970).